

A

B

C

D

E

F

1

1

VCC1<-1S0->VDD, VCC2, VEE2  
AGND1<-1S0->DGND=AGND2

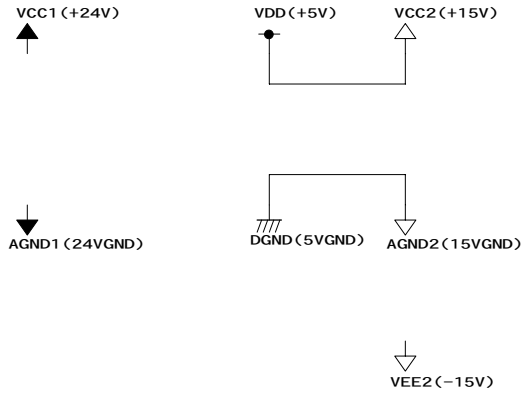

- 1: D/A1+
- 2: D/A2+
- 3: D/A3+
- 4: D/A4+
- 5: FG
- 6: D/A1-
- 7: D/A2-
- 8: D/A3-
- 9: D/A4-

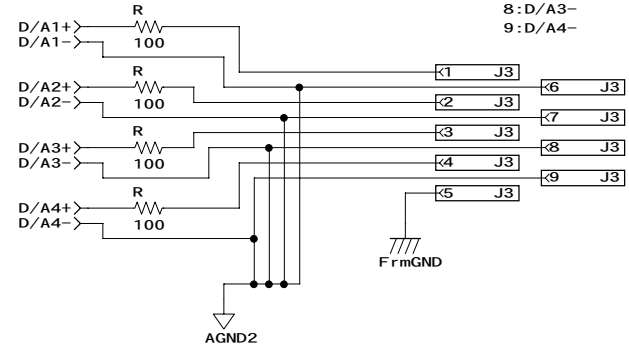

ANALOG OUT

- 1: A/D1+
- 2: A/D2+
- 3: A/D3+
- 4: A/D4+
- 5: FG
- 6: A/D1-
- 7: A/D2-
- 8: A/D3-
- 9: A/D4-

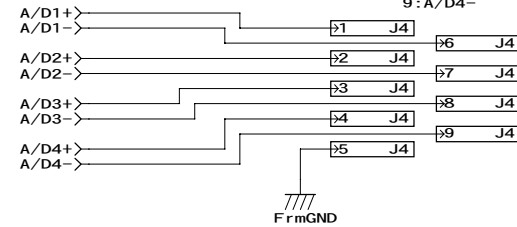

ANALOG IN

3

3

4

4

Effect1.4

TITLE <b>CCL-A4D4</b>		承認
IF		Page /
サイズ A4	図番 <b>C591-IF</b>	Rev. 02
作成. 2001/03/13 更新. 01/03/13		
ヨシオ電子株式会社 東京都東久留米市前沢 3-1-3-1 Tel. 0424-71-2587 Fax. 0424-71-2588		技術設計部 三浦 広志

A

B

C

D

E

F